

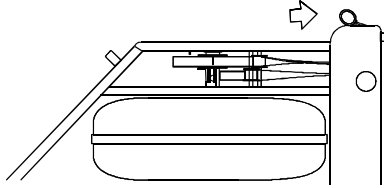

## S4 Monitor Retrofit

**Step 1-**Remove the Handle from the handle rests and place the handle in the full forward position as shown.



**Step 2-**Stand the WaterRower upright and disconnect the bungee as shown.

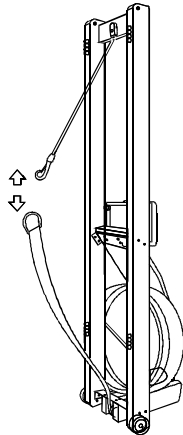

**Step 3-**Lay the WaterRower down. Remove the tie rods and JCB bolts connecting the top deck to the tank assembly as shown.

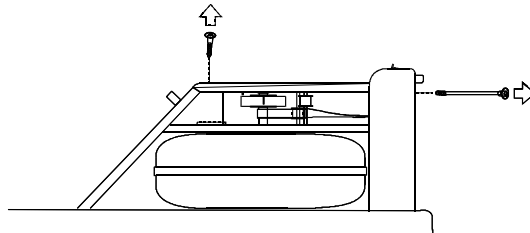

**Step 4-**Remove the top deck assembly as shown, being careful not to dislodge the guide pulleys. If you are replacing a series III or earleir monitor you may have to disconnect the tacho pulley and tacho motor plug.

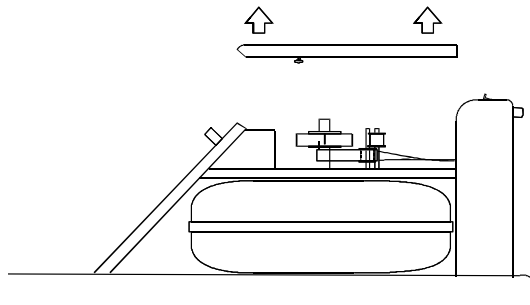

### WaterRower

Europe: 25 Acton Park Estate, The Vale, London, W3 7QE, Tel: +44 (0)208 749 8400  
support@waterrower.co.uk, www.waterrower.co.uk  
America: 560 Metacom Avenue, Warren, RI, 02885, Tel: +1 401 247 7742  
support@waterrower.com, www.waterrower.com



If you are replacing a monitor follow step 5 thru 7. If you are retrofitting a monitor go to Step 8

**Step 5-**Remove the old monitor retaining pin and remove the old monitor from the key bracket

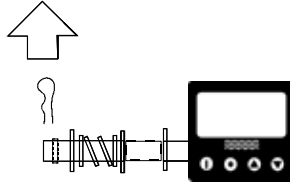

**Step 6-**Remove the old monitor tacho pulley from the clutch

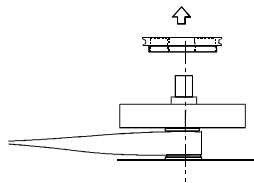

**Step 7-**Remove the battery and battery bracket

**Step 8-**Position the S4 monitor assembly through the right key bracket as shown.

Ensure that the spring and washer orientation is correct. There is a washer on the pin side of the spring. Replace the R pin retaining the monitor assembly as shown. Place the new S4 top deck, top side down, on the top of the tank on the side opposite the monitor. Connect the sensor connector.

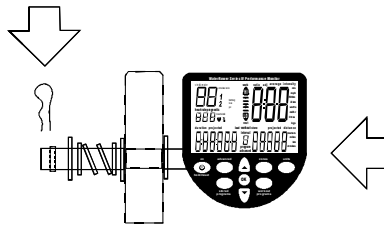

**Step 9-**Place the S4 monitor sensor disk onto the clutch. The internal boss fits around the internal boss of the clutch. If a spacer washer has been supplied, place it on top of the sensor disk.

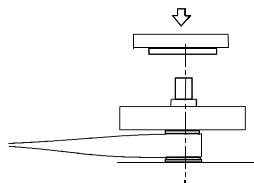

### WaterRower

Europe: 25 Acton Park Estate, The Vale, London, W3 7QE, Tel: +44 (0)208 749 8400  
support@waterrower.co.uk, www.waterrower.co.uk  
America: 560 Metacom Avenue, Warren, RI, 02885, Tel: +1 401 247 7742  
support@waterrower.com, www.waterrower.com



**Step 10-**Replace the S4 top deck as shown.

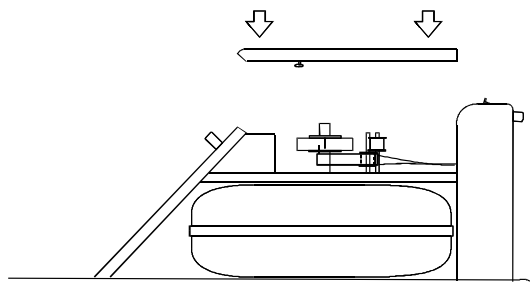

**Step 11-**Replace the JCB bolts and tie rods connecting the top deck to the tank assembly as shown. Ensure that the tie rod cross dowel slots are aligned with the tie rod. You may utilise a screw driver to assist this. Before tightening the screw using a long slender screw driver to lift the tachometer belt onto the tachometer motor pulley and the tachometer clutch pulley.

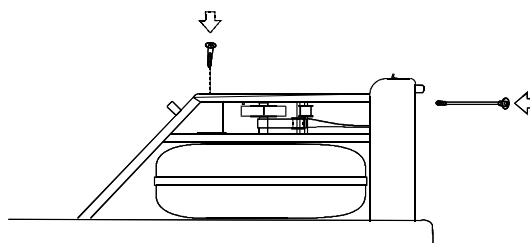

**Step 12-**Stand the WaterRower upright and connect the recoil belt to the bungee as shown.

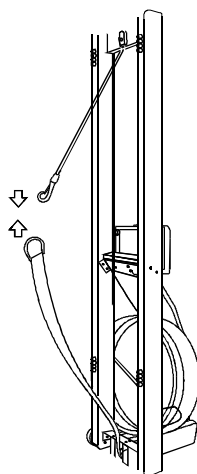

**Note:** If the recoil belt buckle and D-ring have been removed it will be necessary to refit them before Step 9 may be completed. Refer to the Recoil Buckle Replacement Instruction for details

**WaterRower**

Europe: 25 Acton Park Estate, The Vale, London, W3 7QE, Tel: +44 (0)208 749 8400  
support@waterrower.co.uk, www.waterrower.co.uk  
America: 560 Metacom Avenue, Warren, RI, 02885, Tel: +1 401 247 7742  
support@waterrower.com, www.waterrower.com