

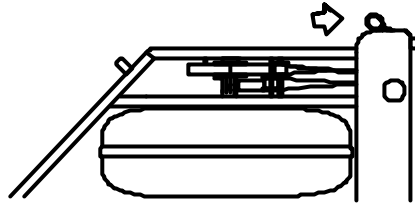

Series III Monitor Retrofit

Step 1- Remove the Handle from the handle rests and place the handle in the full forward position as shown.



Step 2- Stand the WaterRower upright and disconnect the bungee as shown.

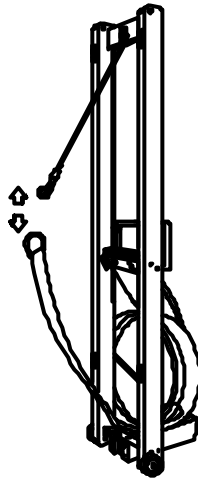

Step 3- Lay the WaterRower down. Remove the tie rods and JCB bolts connecting the top deck to the tank assembly as shown.

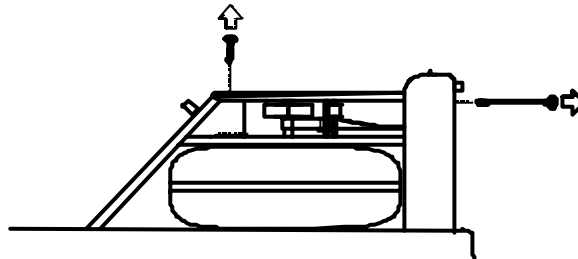

Step 4- Remove the top deck assembly as shown, being careful not to dislodge the guide pulleys. You may have to disconnect the tacho pulley. Disconnect the tacho motor plug.

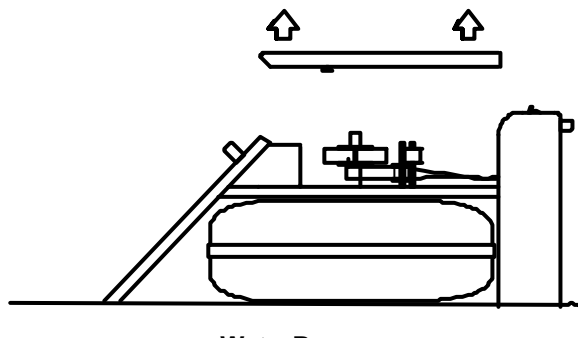

WaterRower

Europe: 25 Acton Park Estate, The Vale, London, W3 7QE, Tel: +44 (0)208 749 8400
support@waterrower.co.uk, www.waterrower.co.uk
America: 560 Metacom Avenue, Warren, RI, 02885, Tel: +1 401 247 7742
support@waterrower.com, www.waterrower.com
Asia: E2, 27-29 Fariola Street, Silverwater, NSW 2128, Tel: +61 (0)2 9748 0591
support@waterrower.com.au, www.waterrower.com.au



Step 5- Replace the tachometer as shown.

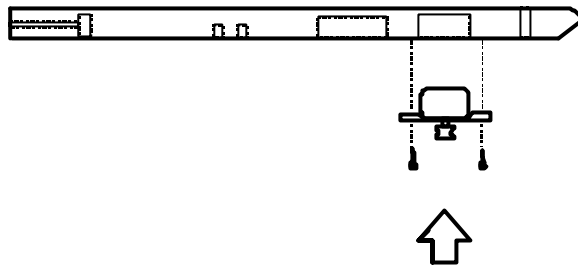

Step 6- Fit the Battery Holder.

Remove the rear bolt from the left (as you are sitting on the machine) Key Bracket.

The one closest to the stopper hole where you fill the water.

Fit the battery holder with this bolt

Fit the battery between the fingers of the Battery Holder (ensure the battery terminals are away from the footboard)

Step 7- Position the monitor assembly from the right key bracket as shown. Ensure that the spring and washer orientation correct. There is a washer either side of the key bracket and washers either side of the spring.

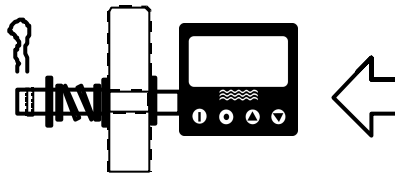

Step 8- Replace the R pin retaining the monitor assembly as shown. Reconnect the tachometer motor plug and the battery.

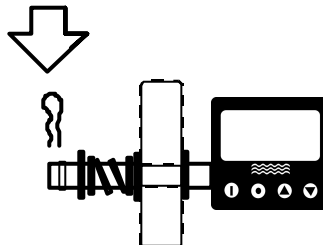

WaterRower

Europe: 25 Acton Park Estate, The Vale, London, W3 7QE, Tel: +44 (0)208 749 8400

support@waterrower.co.uk, www.waterrower.co.uk

America: 560 Metacom Avenue, Warren, RI, 02885, Tel: +1 401 247 7742

support@waterrower.com, www.waterrower.com

Asia: E2, 27-29 Fariola Street, Silverwater, NSW 2128, Tel: +61 (0)2 9748 0591

support@waterrower.com.au, www.waterrower.com.au



Step 9- Replace the tacho belt and replace the top deck as shown.

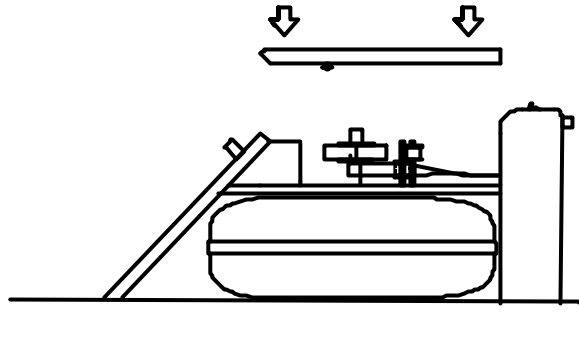

Step 10- Replace the JCB bolts and tie rods connecting the top deck to the tank assembly as shown. Ensure that the tie rod cross dowel slots are aligned with the tie rod. You may utilise a screw driver to assist this. Before tightening the screw, using a long slender screw driver to lift the tacho belt onto the tach motor pulley and the tacho clutch pulley.

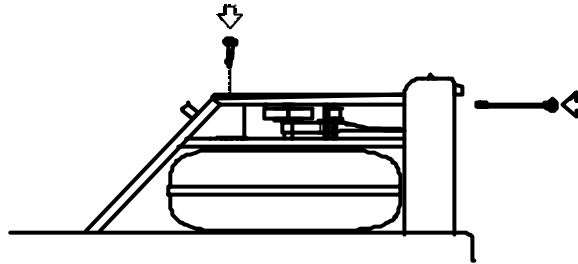

Step 11- Stand the WaterRower upright and connect the recoil belt to the bungee as shown.

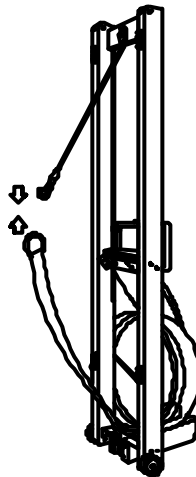

Note: If the recoil belt buckle and D-ring have been removed it will be necessary to refit them before Step 9 may be completed. Refer to the Recoil Buckle Replacement Instruction for details

WaterRower

Europe: 25 Acton Park Estate, The Vale, London, W3 7QE, Tel: +44 (0)208 749 8400

support@waterrower.co.uk, www.waterrower.co.uk

America: 560 Metacom Avenue, Warren, RI, 02885, Tel: +1 401 247 7742

support@waterrower.com, www.waterrower.com

Asia: E2, 27-29 Fariola Street, Silverwater, NSW 2128, Tel: +61 (0)2 9748 0591

support@waterrower.com.au, www.waterrower.com.au