

INDOOR[™] ROW

with **WaterRower**

ASSEMBLY MANUAL

Main Parts

- A Mono Rail Assembly (with seat)
- B Tank Assembly
- C Sub Rails × 2
- D Footboard

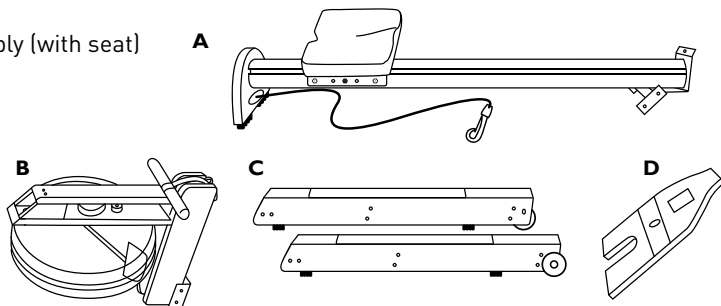

Other Parts

- E JCB 23mm (WRB-B700) × 8
- F JCN (WRP-B711) × 8
- G Handle Rest (WRP-P430) × 2
- H Handle Rest Bolt (WRP-P455) × 2
- I Clamp Bar Bolt (WRP-P1140) × 1
- J Rail Sub Bracket Bolt (WRP-S210) × 1
- K Back of Footboard Bolt (WRP-B720) × 4
- L Rail Sub Bracket (WRP-R1500) × 1
- M 5mm Allen Key (WRP-B740) × 1
- N Heel Rests (WRP-P1700) × 2
- O Syphon Pump (WRP-B405) × 1
- P Chlorine Tablets (WRP-B960) × 3

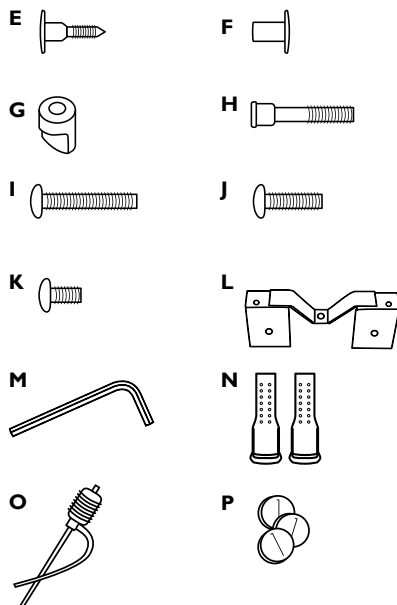

Step 1

Lay the sub rails on the floor with ends parallel. Dolly wheels on the outside.

Attach the end of the mono rail to the angled ends of the sub rails with the Allen key (M) and 4 pairs of the JCN nuts (F) and JCB bolts (E) .

Do not tighten all the way.

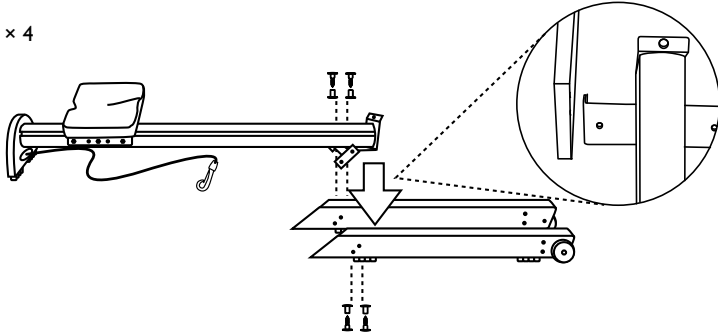
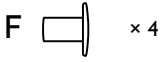
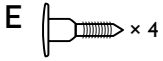

Step 2

Place the tank assembly on the sub rails in the direction shown in the picture below.

Using the Allen key (M) and 4 pairs JCN nuts (F) and JCB bolts (E), attach the forward riser bracket to the rails. You may need to apply slight pressure to align bracket and rail holes. Do not tighten all the way.

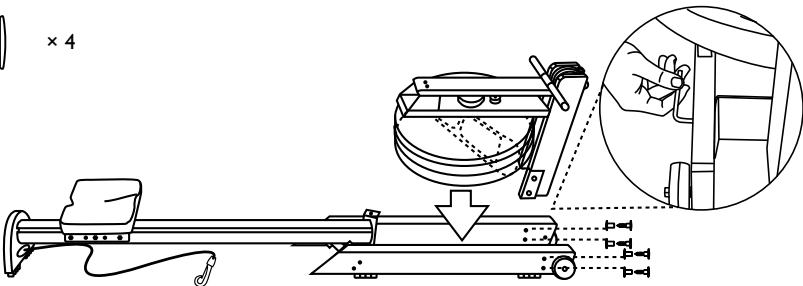
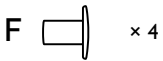
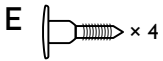

Step 3

Place the footboard on the rails, then attach the sensor cable to the monitor cable protruding from the back of the footboard.

The sensor cable may be taped to the back of the footboard. If so, remove the tape.

Feed the cable gently through the brackets so it does not get trapped between the footboard and tank assembly.

Align gold rivnuts on the tank assembly with the footboard's handle rest holes.

It may be necessary to slightly loosen the 2 bolts on the top deck to allow the footboard clearance.

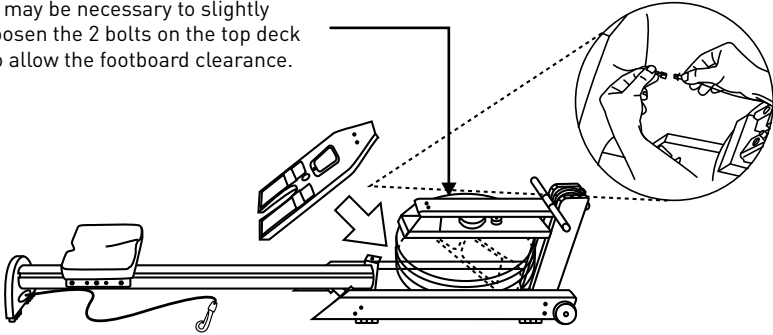

Step 4

Using the 5mm Allen key (M), screw the handle rests and bolts (G & H) through the top of the footboard into the rivnuts mentioned in the previous step.

Do not over tighten these bolts.

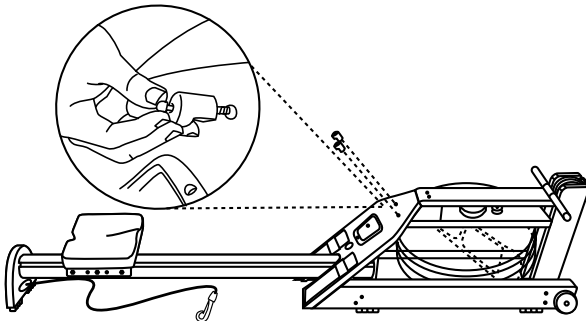
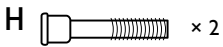

Step 5

Tighten the footboard to the mono rail by screwing in the clamp bar bolt (I).

Do not tighten all the way.

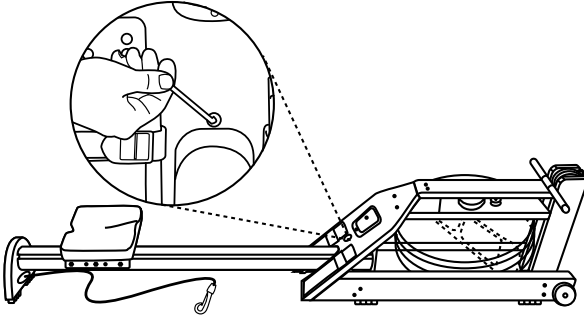
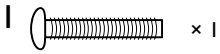

Step 6

Stand the machine up and insert two of the back of footboard bolts (K) into the footboard bracket.

Having kept all the bolts loose will allow easier alignment of the bolts and rivnut holes in the footboard.

Do not tighten all the way.

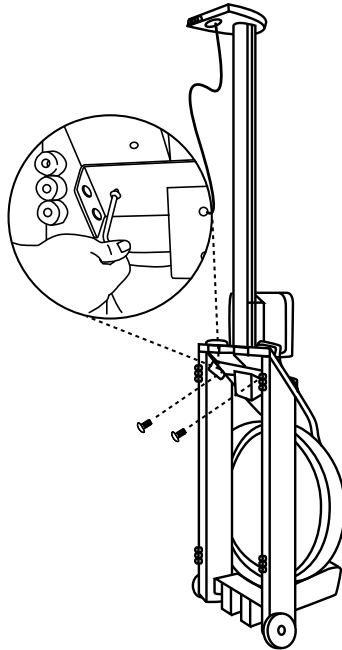

Step 7

Insert the sub bracket bolt (J) through the “U” in the rail sub bracket (L) into the rail, to hold the bracket in place for step 8.

Step 8

Screw in the rail sub bracket (L) underneath the footboard using the 2 remaining back of footboard bolts (K). Tighten all the way.

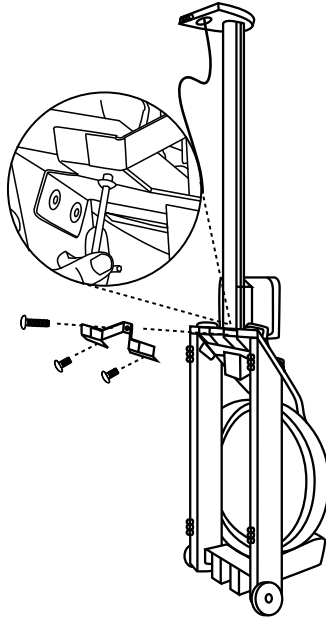
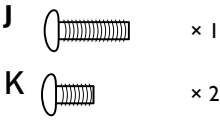

Step 9

Go back and tighten all the bolts in steps 1, 2, 5, and 6. Also tighten the 4 bolts on the front of the rower (below forward riser bumpers, see tag). Leave the bolts in step 4 and 7 alone. Should you experience any problem with aligning the components, loosen all bolts, align and retighten.

Step 10

Tighten the rail sub bracket bolt (J) (Step 7) so that there is 1/4" (6mm) between the bracket and rail.

Do not tighten all the way, leave 1/4" (6mm) of the bolt between the bracket and rail.

This bolt controls the tension on the rower. If the front end lifts while rowing, tighten the bolt. If the mid section lifts while rowing, loosen this bolt.

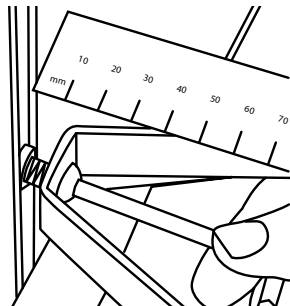

Step 11

Unwrap the recoil belt from the forward riser bracket, making sure the belt runs below and around the pulley.

Attach the D ring on the recoil belt to the bungee hook.

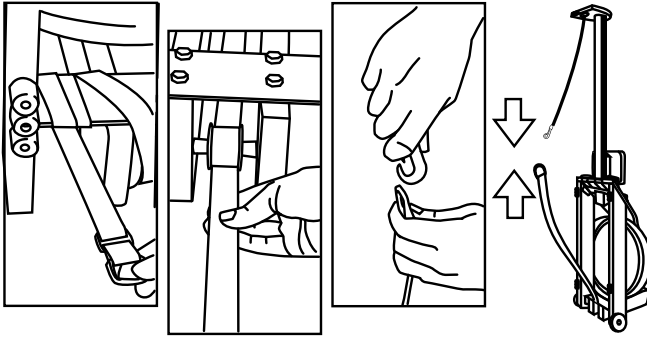

Step 12

Lay the unit flat and remove the tank stopper from between the top and bottom deck. Use the included syphon pump (O) to fill the tank to the level indicated on the level gauge sticker located on the underside of the tank. (See next page.)

Do not fill above the "19" level mark.

Insert one chlorine tablet (P) every six months. Additional chlorine tablets are available upon request.

Moisten the tank stopper to assist with replacement.

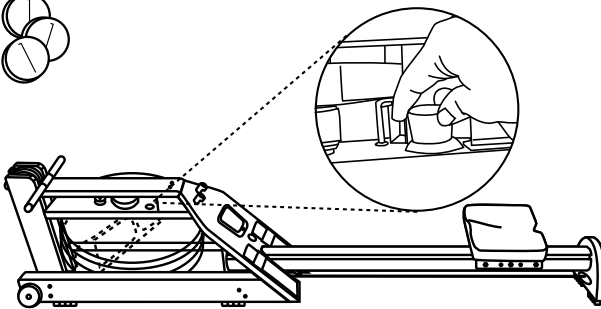
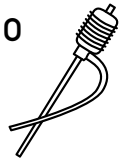

How to Fill and Empty the Tank

- 1) To pump water, turn the knob clockwise to close valve as shown in figure A
- 2) Locate water source above (higher than) water destination:
 - See Figure B for filling tank
 - See Figure C for emptying tank
- 3) Squeeze pump 4-5 times until water flows
- 4) Turn knob counter-clockwise to allow air into the pump and end syphon.

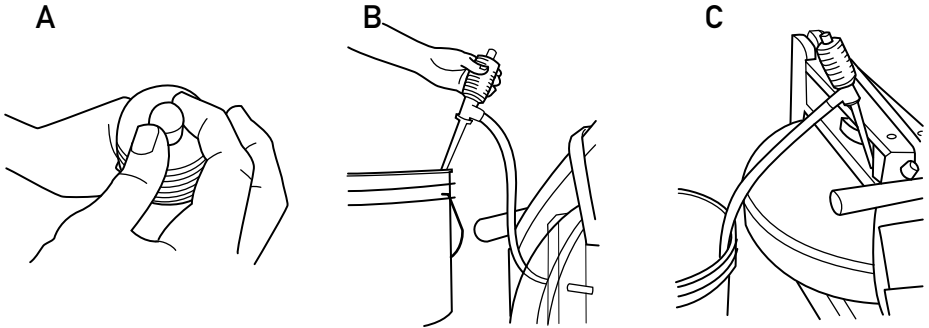

The Level Gauge

The level gauge is located on the bottom of the tank. To find it, stand the machine up, and look between the two sub rails.

Information found on the sticker includes the Serial Number (along the top), contact information (middle) and the level gauge (second half).

Recommended Water Levels:

Level 15 - 16: Beginner

Level 16 - 18: Intermediate

Level 18 - 19: Advanced

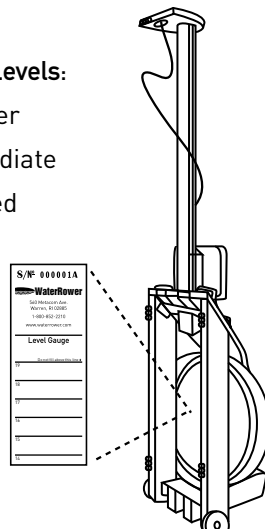

Troubleshooting Tips

- 1 Loosening bolts - overtime and with use bolts can come loose, use the 5mm Allen key to gently tighten the bolts. If the bolts continue to loosen use a small amount medium strength Loctite® to fasten the nuts and bolts more securely.
- 2 Monitor not turning on - check the batteries positioned behind the monitor. Unscrew the monitor and gently lift to access the battery pack.
- 3 Monitor not counting down - check the monitor and sensor connector is connected. Check all wiring is intact.
- 4 Paddle not turning smoothly, loosen all tank bolts and retighten.

For other troubleshooting and service tips, please visit www.waterrowerservice.com or contact WaterRower at support@waterrower.com or call 800 852 2210.

Notes

Make note of the serial number. This number can be found on the level gauge sticker and is required when contacting WaterRower for customer support.

S/N^o: _____

If you have any questions or comments about the assembly or use of this unit, please contact support@waterrower.com or the numbers below.



560 Metacom Ave. Warren, RI 02885
T: (401) 247-7742 – F: (401) 247-7743